

MODELS 461.217 /219 /223 /227 /229 /238 /239 /249 /266 /267 /302 /321 /322 /323 /326 /327 /328 /329 /332 /335 /336 /337 /338 /341 /342 /345 /365 /366 /367 /368 /401 /402 /403 /404 /405 /450 /451 /452 /454 /455 /456 /458 /459

MODEL 463.200 /204 /206 /207 /208 /209 /220 /221 /224 /225 /227 /228 /230 /231 /232 /233 /240 /241 /300 /304 /307 /308 /320 /321 /324 /325 /327 /328 /330 /331

Removal of the airbag unit

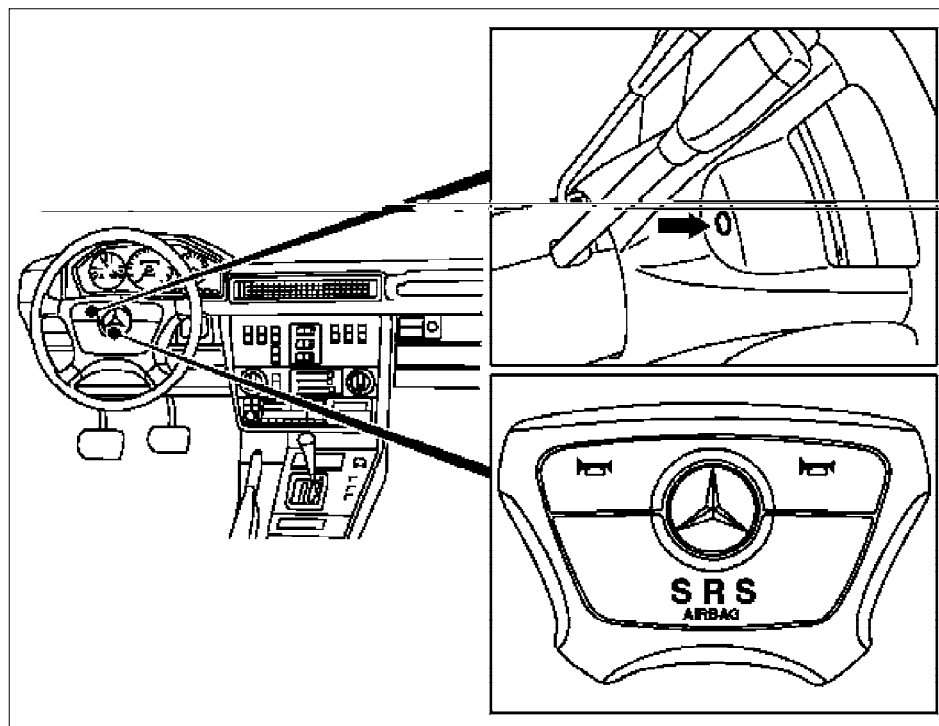

P91.60-0475-06

Operation no. of operation texts or standard texts and flat rates

Category	Op. no.	Operation text
G	912157	REPLACE DRIVER AIRBAG UNIT

	Remove/Install		
Danger!	Risk of injury when carrying out test or repair work on airbag or emergency tensioning retractor units	Store airbag unit with expulsion area on top, do not subject to temperatures above 100 °C. Interrupt power supply when working on such units.	AS91.00-Z-0001-01A
	Important instructions for performing repair, body work and welding on vehicles with airbags or belt tensioner units		AH91.00-P-0002-01B
	Evaluation of airbags and emergency tensioning retractors on accident vehicles		AH91.00-P-0006-01B
	Legal regulations concerning the handling and storage of airbag and emergency tensioning retractors		AH91.00-P-0004-01A
1	Withdraw ignition key		
2	Unscrew two screws (arrow)	At the same time hold the airbag unit. 	*BA91.60-P-1001-01B *126589001000
3	Lift off the airbag unit from the steering wheel and detach the plug-in connector from the squib on the gas generator	Installation: connector must be heard to engage when being plugged in.	
4	Remove airbag unit from steering wheel	If the airbag unit is replaced, dispose of the faulty one in a proper manner.	
OS	Notes on disposal of airbags and emergency tensioning retractors	All models Make airbag units unusable.	OS91.00-P-0001-01A AR91.60-P-0611A

5	Install in the reverse order	 The steering wheel must always be replaced after the driver airbag unit has deployed.	
6	Check the automatic resetting of the combination switch		
7	Carry out diagnosis	See Diagnosis Manual, Body	

 **Airbag**

Number	Designation		Model 461	Model 463 up to 31.11.00	MODEL 463 as of 1.12.00
BA91.60-P-1001-01B	Bolt, airbag to steering wheel	Nm	6	6	8

Special tools

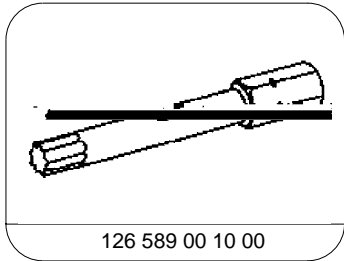

126 589 00 10 00

Screwdriver bit

MODELS 461.217 /219 /223 /227 /229 /238 /239 /249 /266 /267 /302 /321 /322 /323 /326 /327 /328 /329 /332 /335 /336 /337 /338 /341 /342 /345 /365 /366 /367 /368 /401 /402 /403 /404 /405 /450 /451 /452 /454 /455 /456 /458 /459, 463.200 /204 /206 /207 /208 /209 /220 /221 /224 /225 /227 /228 /230 /231 /232 /233 /240 /241 /300 /304 /307 /308 /320 /321 /324 /325 /327 /328 /330 /331

Using Model 463 as an example

- 1 Impact absorber (up to 4.94)
- 1 Airbag unit (as of 4.94)
- 2 Countersunk head bolt
- 3 Identification on steering wheel and steering shaft

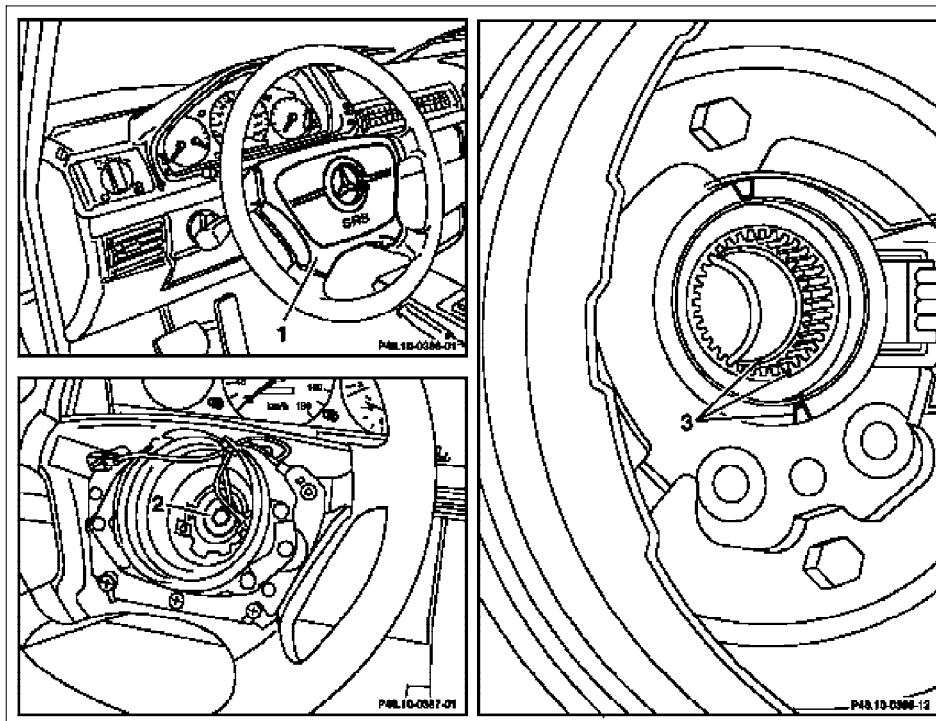

P46.10-0366-06

Shown on model 461.302

- 32 Steering wheel
- 32C Countersunk head bolt



P46.10-2372-01

Operation no. of operation texts or standard texts and flat rates

Category	Op. no.	Operation text
G	468220	REMOVE AND INSTALL STEERING WHEEL CONDITION

	Remove/Install		
	Legal regulations concerning the handling and storage of airbag and emergency tensioning retractors	Models 124, 129, 140, 163, 168, 170, 202, 208, 210, 314, 316, 318, 461, 463, 638, 901, 902, 903, 904, 950, 952, 953, 954.	AH91.00-P-0004-01A
1.1	Remove impact absorber (1) from steering wheel	Up to 4.94	
1.2	Remove airbag unit (1) from steering wheel	As of 4.94	AR91.60-P-0660A
2	Turn steering wheel into center position	Wheels must be in straight-ahead position.	
3	Unscrew countersunk head bolt (2), (32C)	Replace countersunk head bolt (2), (32C) when installing. 	*BA46.10-P-1001-02A
4	Mark center position (3) on steering wheel and steering shaft.	New vehicles are identified on the steering wheel and steering shaft at the plant.	

5	Pull off steering wheel	i Installation: Observe marking on steering wheel and steering shaft. Check position of steering wheel during road test.	
6	Install in the reverse order		

Nm Retarder

Number	Designation		Model 461	Model
				463.200/204/206/207/ 208/209/220/221/224/ 225/227/228/230/231/ 232/233/240/241/243/ 244/245/246/247/248/ 249/250/254/300/304/ 307/308/309/320/321/ 322/323/324/325/327/ 328/330/331/332/333
BA46.10-P-1001-02A	Bolts, steering wheel to steering shaft	Nm	80	80

MODEL 463 (except 463.244 /245 /247 /248 /249 /250 /254 /309 /322 /323 /332 /333)

A45 Fanfare horns and airbag contact spiral

S4 Combination switch

S40 Cruise control switch

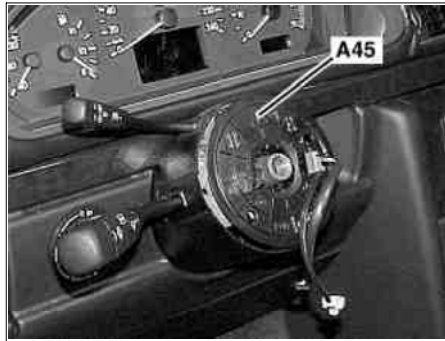

P46.10-2125-01

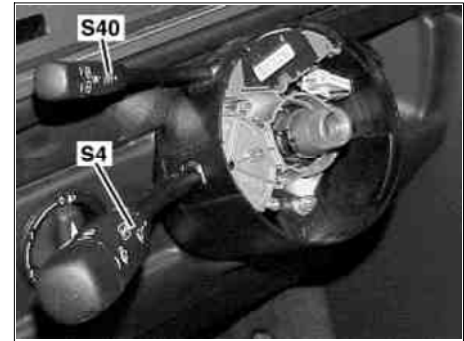

P54.25-2311-01

2 Wood trim strip

3 Cover

4 Headlamp range adjuster





L10 Transponder coil

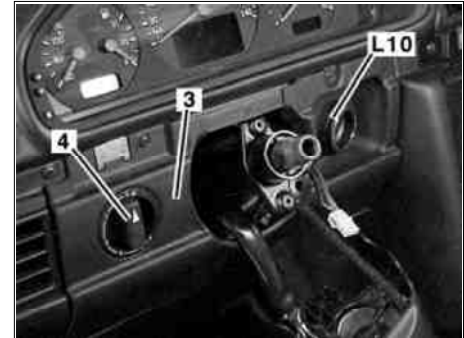

P68.30-2173-01



P68.10-2273-01

	Removing, installing		
1	Remove/install steering wheel		AR46.10-P-0100G
2	Remove contact spiral (A45)	 Installation: Observe center position	
3	Unscrew combination switch (S4) and cruise control switch (S40)		
4	Remove wood trim strip (2)	 The wood trim strip is in two sections up to ident. no. 110196  Lever out carefully. The retaining lugs may break off. Especially those on the short two-part wood trim strip. Do not bend the wood trim strip	
5	Unscrew cover (3)	 Do not unscrew, kink or open the headlamp range adjuster (4).	
6	Pull transponder coil (L10) off steering wheel lock		
7	Install in the reverse order		

MODEL 463 up to 30.11.00

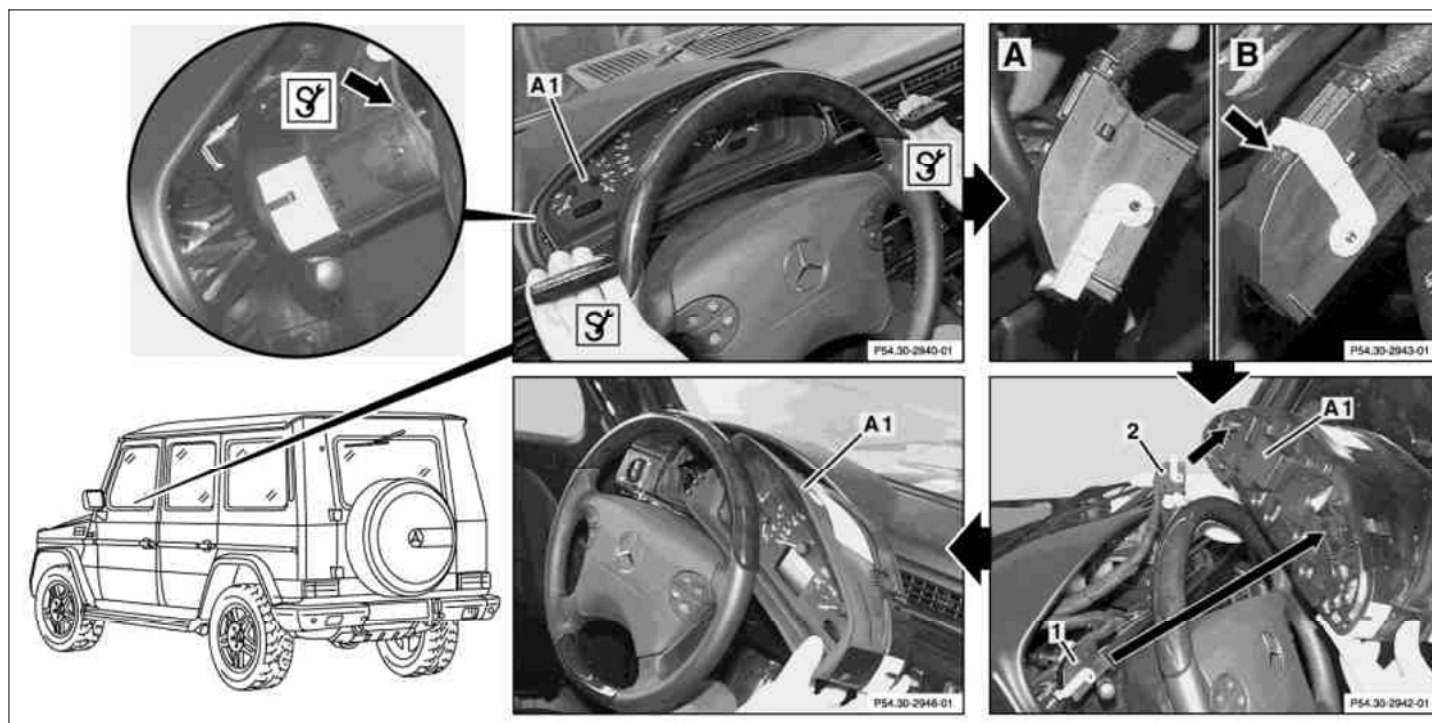

P54.30-2947-09

TO1 Instrument cluster

1 Electrical connection
2 Electrical connection

A Connection disengaged
B Connection engaged

Operation no. of operation texts or standard texts and flat rates

Sector	Op. no.	Operation text
P	546015	INSTRUMENT CLUSTER REMOVAL AND INSTALLATION
P	546023	INSTRUMENT CLUSTER REPLACEMENT (FOLLOWING INSPECTION)

☒ ☒	Removal, installation		
1	Disconnect ground cable of battery	Model 463.241 with code 979 All models except 463.241 with code 979	AR54.10-P-0003PV AR54.10-P-0003G
2	Guide the pulling hook between the dashboard binnacle and the instrument cluster.	⚠ Do not damage instrument cluster. Guide in the pulling hook approx. 5 mm between the dashboard binnacle and the instrument cluster.	*140589023300
3	Pull out instrument cluster (A1).	⚠ Carefully pull left and right, alternately.	
4	Disengage the detent and remove the wiring connector (1).	Fig. A Connection disengaged Fig. B Connection engaged Press the release button (arrow) to disengage the detent.	
5	Disengage the detent and remove the wiring connector (2).	Fig. A Connection disengaged Fig. B Connection engaged Press the release button (arrow) to disengage the detent.	
6	Pull the instrument cluster (A1) to the right to remove.		
7	Install in the reverse order	ℹ Diagnosis of instrument cluster using HHT up to 06.1999, using STAR diagnosis tool as of 06.1999.	

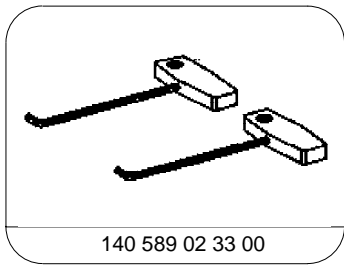

140 589 02 33 00

Pulling hook

MODEL 463.200 /204 /206 /207 /208 /209 /220 /221 /224 /225 /227 /228 /230 /231 /232 /233 /240 /241 /300 /3 04 /307 /308 /320 /321 /324 /325 /327 /328 /330 /331

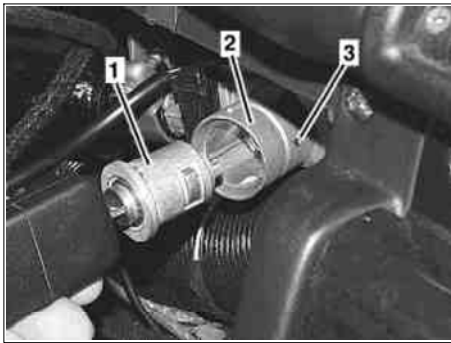

P46.10-2122-01

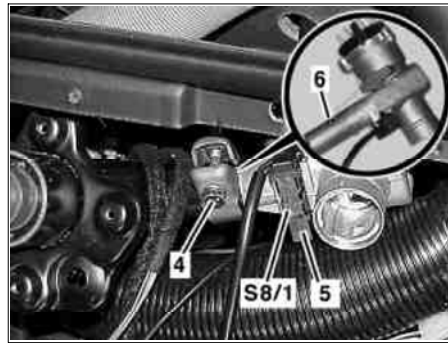

P46.10-2123-01

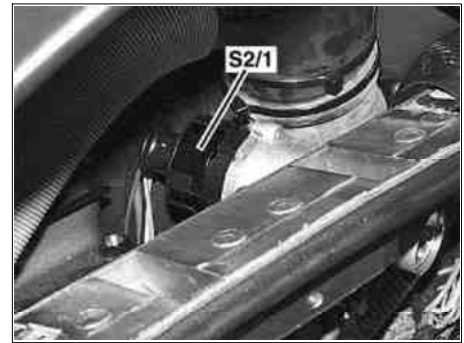

P46.10-2124-01

- 1 Ignition switch
2 Steering wheel lock
3 Ignition switch release bore

- 4 Fixing clamp
5 Warning buzzer switch connection
6 Steering wheel lock locking bolt
S8/1 Warning buzzer switch

- S2/1 Ignition/starter switch

Operation no. of operation texts or standard texts and flat rates

Range	Op. no.	Operation text
g	468010	INSTALL NEW STEERING WHEEL LOCK

	Remove, Install		
1	Remove cover from jacket tube.		AR68.10-P-1060G
2	Remove instrument cluster		AR54.30-P-6015G
3	Remove ignition switch (1) by pressing in locking spring.	i Position wrench in 2nd detent and press locking spring using an aid through the release bore (3) at the steering wheel lock (2).	
4	Remove steering wheel lock (2).	i Unscrew bolt (4) and turn clamp until locking bolt (6) is visible. The locking bolt can only be pressed in when the steering wheel lock is in the 2nd detent.	
5	Disconnect electrical connection (5) at warning buzzer switch (S8/1) and unplug connector at ignition/starter switch (S2/1).		
6	Install in the reverse order	Unclip warning buzzer switch (S8/1) when installing a new steering wheel lock.	
		i The warning buzzer switch can only be unclipped in the 2nd detent of the steering wheel lock.	