

Test values – Chassis

Distance between bearing bores of front transverse link	A	mm	760 ± 0,5
Distance between bearing bores of rear transverse link	B	mm	965 ± 0,5
Front trailing arm	C	mm	706
Rear trailing arm	D	mm	733

Arrangement of transverse link and trailing arm

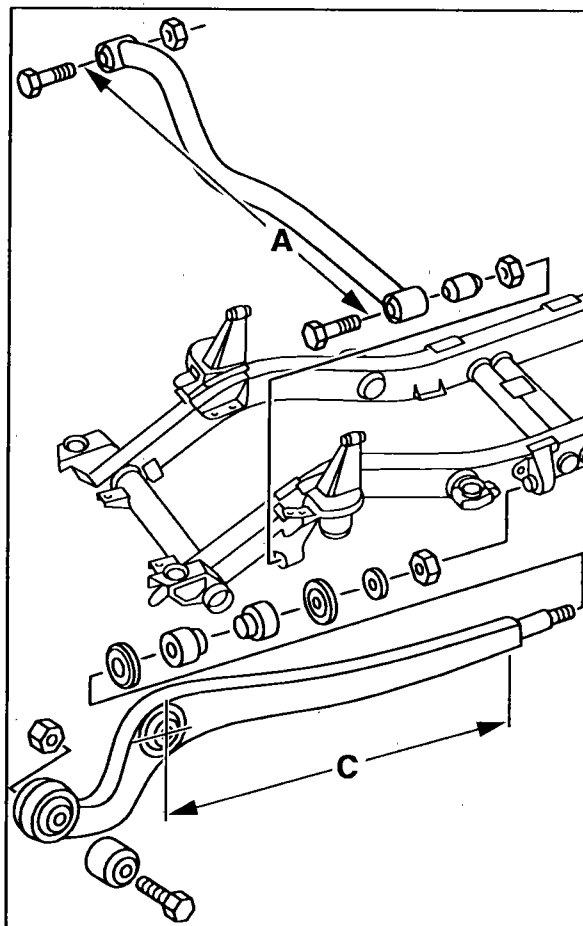

P33.15-0201-17

front

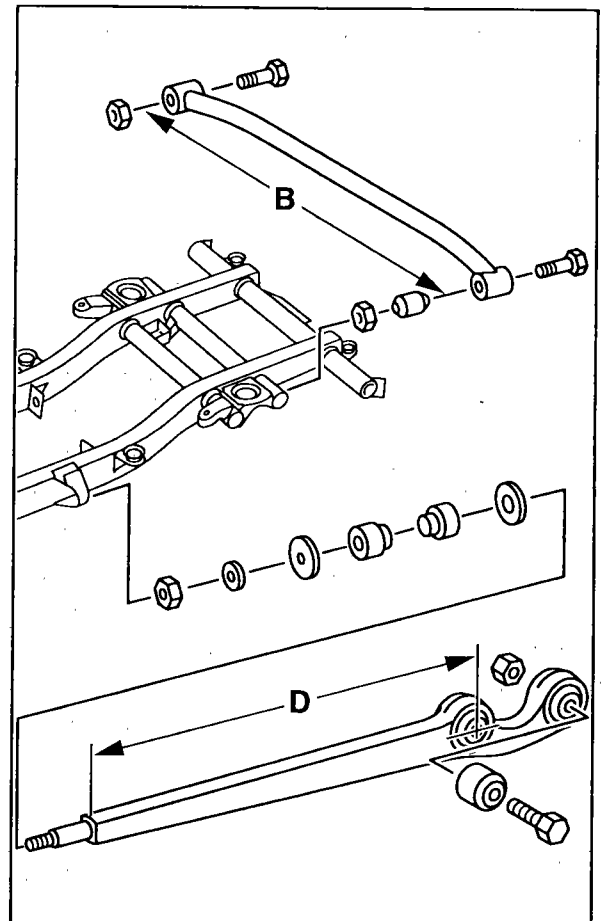

P35.15-0200-17

rear

Note: Checking the trailing arm brackets on the frame is carried out in conjunction with the straightening set, for checking frame on straightening bench, refer to 31.51– 3.1/1.